

Combined Gas and Particle Measurement System

An Instrument Development Project of Air Quality Design, Inc.

August 2010

EXECUTIVE SUMMARY

PROJECT DESCRIPTION

Real-time measurements of particle species including NO_3^- , NH_4^+ , and $\text{SO}_4^{=}$ are needed at multiple locations in and beyond the NCORE network to understand pollutant fluxes, the dynamics of $\text{PM}_{2.5}$, and to constrain atmospheric models. Existing methods have proved problematic for widespread, autonomous deployment creating an opportunity for development of a reliable, autonomous approach. The innovation of the proposed project is use of a proven catalytic, denuder difference method for measurement of the combined gas and particle abundance in combination with inertial separation of the particle species using an inert-surface cyclone to provide a measurement of the gaseous species alone. The difference between the two instrument modes, measured with a single detector, represents the abundance of the particle species. This method is applicable to NO_3^- and NH_4^+ using a standard NO chemiluminescence detector and for measurement of $\text{SO}_4^{=}$ using a standard SO_2 pulsed-fluorescence detector. The objective of the Phase I work was to characterize the response of the catalytic converter and inertial separation systems for the oxidized nitrogen species (HNO_3 and NO_3^-) and the reduced nitrogen species (NH_3 and NH_4^+) using laboratory-based standards.

The primary objectives of the Phase I research were twofold:

1. Demonstrate using laboratory standards the conversion efficiency of the oxidized and reduced nitrogen converters for the target species, including HNO_3 , NO_3^- , NH_3 , and NH_4^+ , and
2. Test the particle separation efficiency for several commercial off-the-shelf inlet cyclones using a controlled particle calibration source.

SUMMARY OF FINDINGS

Instrument development

A schematic diagram of the $\text{HNO}_3/\text{NO}_3^-$ system is shown in **Figure 1**. The $\text{NH}_3/\text{NH}_4^+$ system is comparable, but includes an additional set of catalytic converters to allow measurement of the reduced nitrogen species with the NO detector. Both systems include a temperature controlled cyclone inlet (URG-2000-30ED) and a high flow bypass pump.

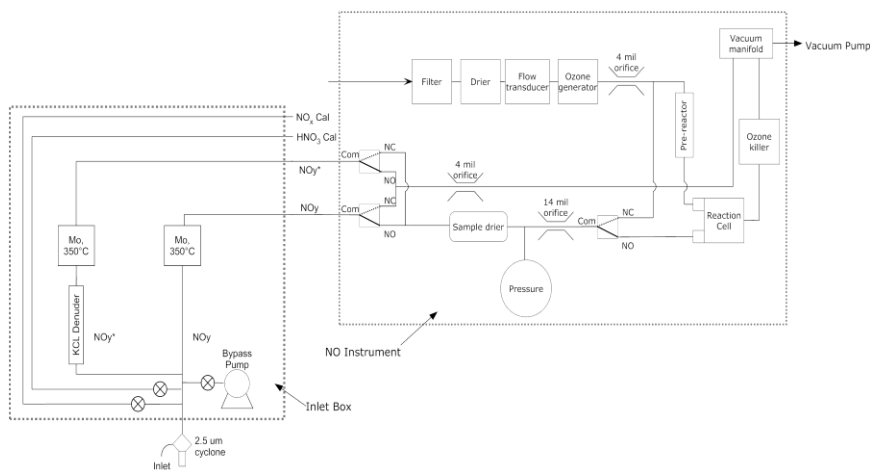

Figure 1. Schematic diagram of the $\text{HNO}_3/\text{NO}_3^-$ inlet system coupled to an API model 200EU NO instrument.

Each inlet box weighs about 15 pounds and is connected to the TAPI model 200EU NO instrument via a 10 meter weather-tight umbilical. Control of the calibration valves, temperature controllers, and bypass pump located within the inlet box is accomplished by communication with an Ethernet-connected DAQ device. **Figure 2** shows both the CAD model and physical prototype created for the $\text{NH}_3/\text{NH}_4^+$ inlet.

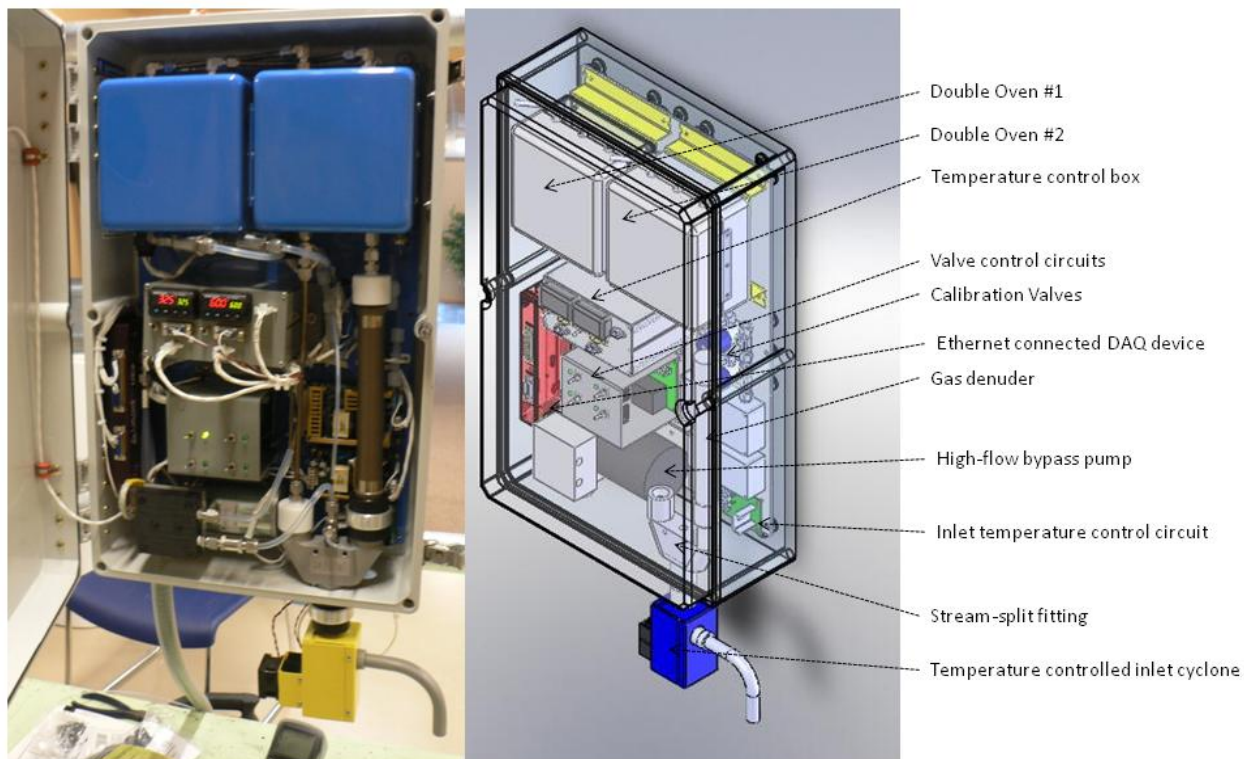

Figure 2. Photograph and CAD model of the $\text{NH}_3/\text{NH}_4^+$ inlet system identifying the major components.

Instrument Characterization

We used a permeation-tube based calibration source to test the denuding efficiency of the sodium carbonate (HNO_3) and citric acid (NH_3) denuders. The denuders were aluminum body, concentric glass interior, 242 mm long denuders manufactured by URG Corporation (Chapel Hill, NC). The NH_3 and HNO_3 systems were operated sampling ambient air through the course of the denuder efficiency study. Each system was challenged on a daily basis via standard addition of either NH_3 or HNO_3 calibration gas from the permeation source. The concentration of the NH_3 was about 200 ppbv, while the concentration of the HNO_3 was about 20 ppbv. Over the course of the 60 days operated the average efficiency for both denuders was greater than 90%. Our conclusion for the denuder efficiency study is that the capacity of the denuders is high enough that the necessary maintenance period should be no more frequent than one month. Conversion efficiency was measured to be greater than 95% for both HNO_3 and NH_3 on the respective systems.

To test the inertial separation of particles from the whole air sample we used two different particle generators which allowed characterization of the two-speed cyclone at the extremes of the ambient particle size range. For the upper end of the size spectrum we used a TSI Vibrating Orifice Aerosol Generator (VOAG), that was tuned to deliver particles on the order of 1-5 μm . For the lower end of the ambient size spectrum we used a TSI atomizer that allowed generation of particles with a mean diameter of 0.1-0.3 μm . We used an aqueous solution of

NH_4NO_3 in both generators in concentration ranging from 0.1-10 g/L. The results of the particle challenges to the instruments showed that the high speed cyclone removes virtually all of the particles >1 mm, and 95% of the particle >0.2 mm. This result is shown graphically in **Figure 3**, which presents results of the small diameter particle testing.

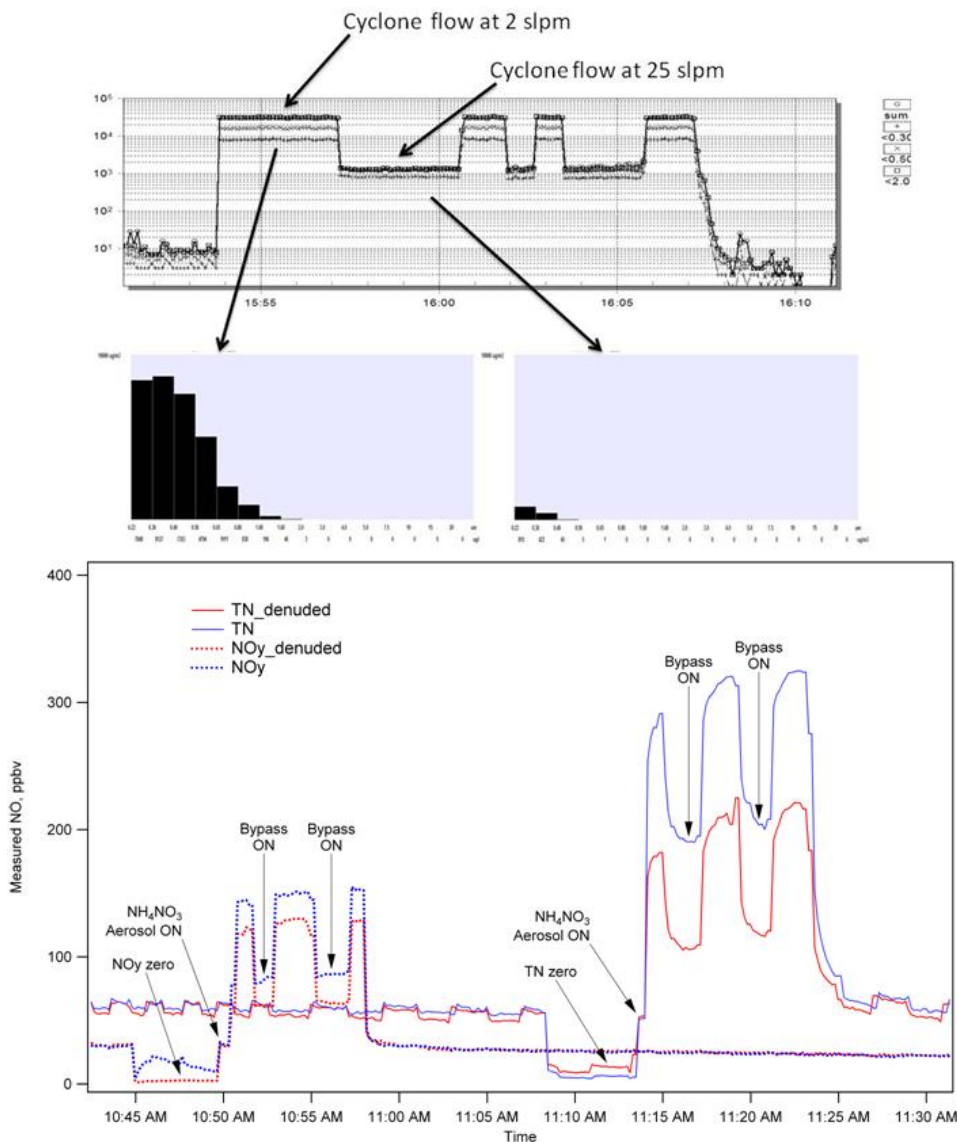

Figure 3. Results from instrument characterization using the TSI model 3076 atomizer with an aqueous NH_4NO_3 solution. The top panel shows measurements using a particle spectrometer downstream of the inlet cyclone. The bottom panel shows the chemical measurements using the same generator.

CONCLUSIONS

The Phase I research project “Combined Gas and Particle Measurement System” showed excellent results. Specifically, the conversion efficiency of the catalytic converters for both the reactive gases HNO_3 and NH_3 and their particulate analogs was $>95\%$; the collection efficiency of the reactive gas denuders was shown to be $>90\%$ over a 60 day period; the high speed cyclone was shown to remove the particulate portion of the whole air sample while allowing passage of the reactive gases. The Phase II research will focus on optimization of the cyclone acceptance/rejection spectrum and seamless integration of the inlet system with commercial instrumentation.

PUBLICATIONS

We are currently working on a patent application for use of the particle cyclone in a two-speed mode and also on a technical publication of the results of both this research and related work using the two-speed cyclone.

COMMERCIALIZATION

We are working with the commercial instrument manufacturer Teledyne-Advanced Pollution Instruments (TAPI) to initiate integration of the inlet system developed in this research with their model 200 EU NO instrument. Our plan is to include TAPI in the Phase II research project in the role software development and system characterization. Further involvement could include incorporation of the product in their sales and marketing to best make the technology available to the air quality research community.